

cirkit screen system

(Part 2) Cirkit table fixed screens

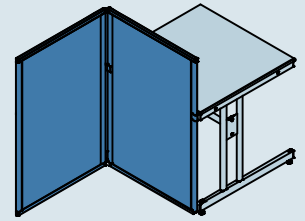

contents	page
Screen overview	1
Counter screen overview	2
Screen sizes	3
Screen fitted to cirkit base table	4
Screen fitted to cirkit add-on table	5
Screen fitted to end of cirkit table	6
Screen fitted to cirkit corner table	7



METALLIFORM
Chambers Road
Hoyland, Barnsley
S74 0EZ

tel. 01226 350555

[cfg] reserves the
right to amend details and
specification in this brochure

circuit - screen overview

(Part 2) Circuit table fixed screens

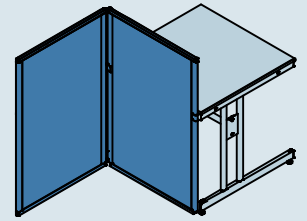
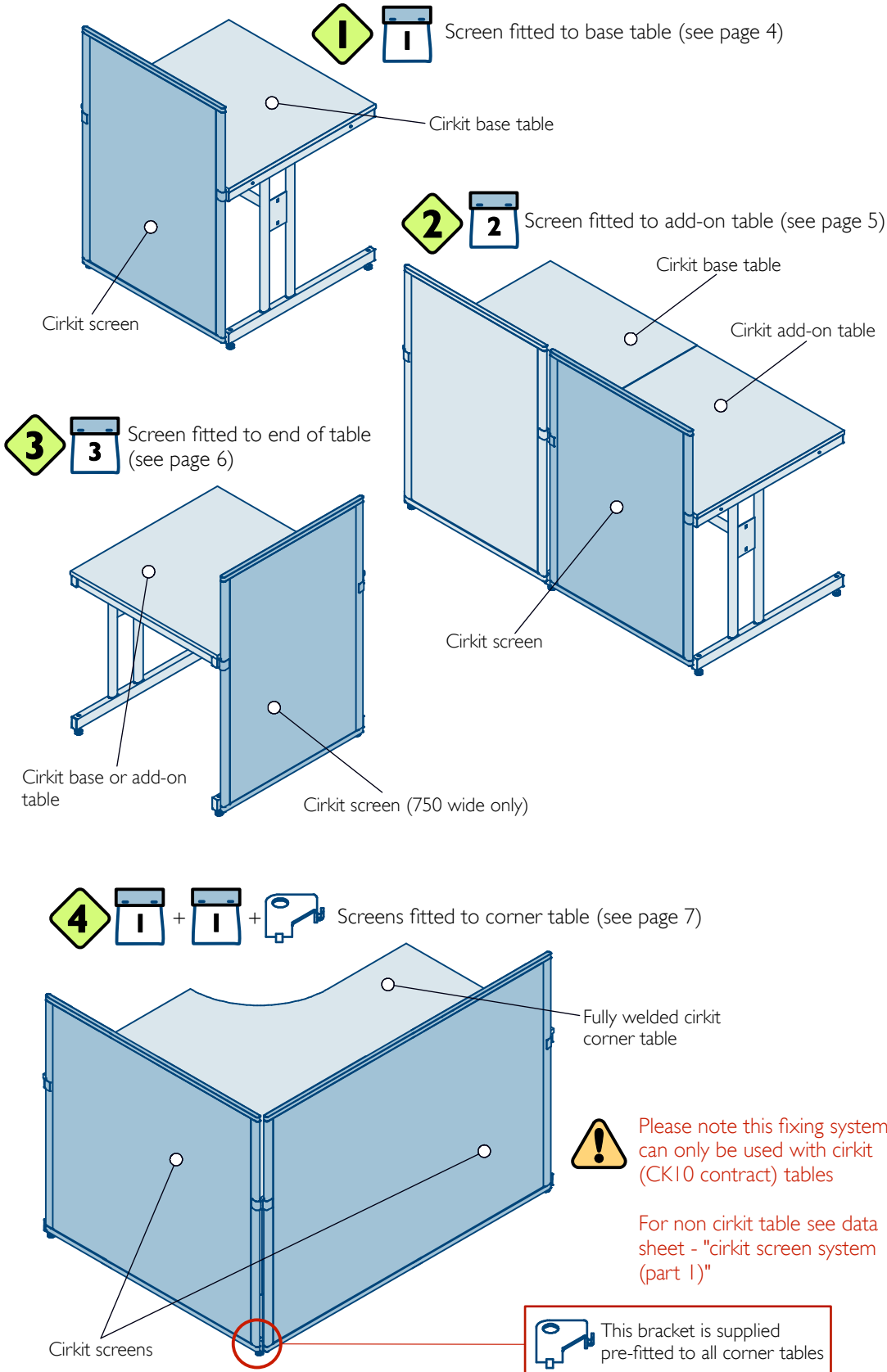

screen fixing packs for use with circuit tables

Screen pack 1 - ref 3285

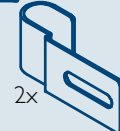

Screen top bracket type A

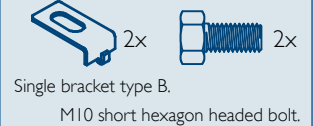
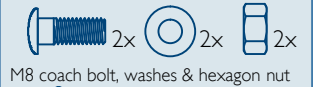

Screen pack 2 - ref 3286

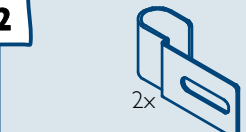

Screen top bracket type A

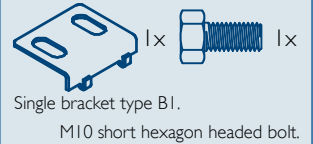
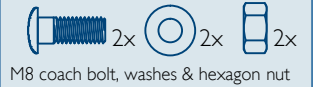

Screen pack 3 - ref 3287



Screen top bracket type A

Bottom bracket type D (no fixings required)

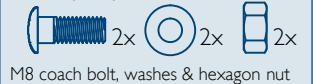

METALLIFORM
Chambers Road
Hoyland, Barnsley
S74 0EZ

tel. 01226 350555

[cfg] reserves the right to amend details and specification in this brochure

cirkit - counter screen overview

(Part 2) Cirkit table fixed screens

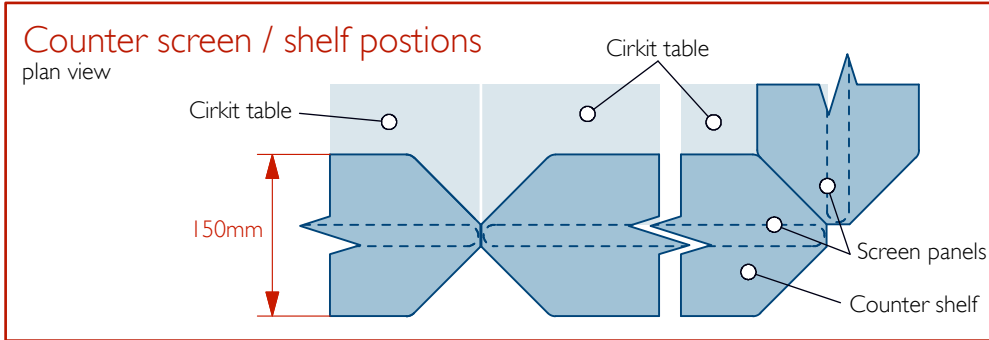
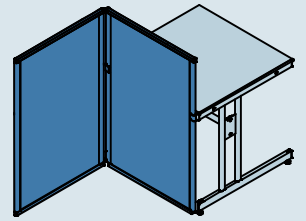

screen fixing packs
for use with cirkit tables



Screen pack 1 - ref 3285

- 2x Screen top bracket type A
- 2x M8 coach bolt, washes & hexagon nut
- 2x Single bracket type B
- 2x M10 short hexagon headed bolt



Screen pack 2 - ref 3286

- 2x Screen top bracket type A
- 2x M8 coach bolt, washes & hexagon nut
- 1x Single bracket type B1
- 1x M10 short hexagon headed bolt



Screen pack 3 - ref 3287

- 2x Screen top bracket type A
- 2x Bottom bracket type D (no fixings required)
- 2x M8 coach bolt, washes & hexagon nut

manufactured by



METALLIFORM
Chambers Road
Hoyland, Barnsley
S74 0EZ

tel. 01226 350555

[cfg] reserves the right to amend details and specification in this brochure

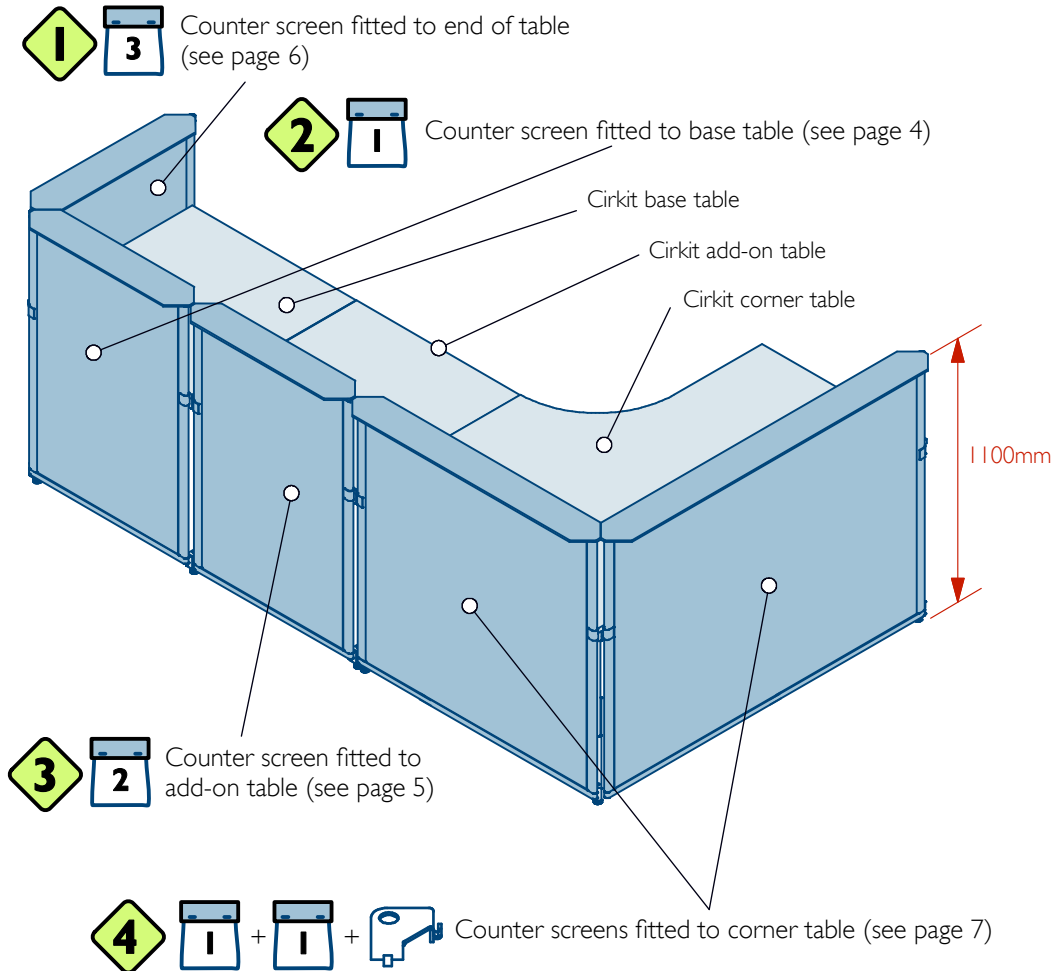

Please note this fixing system can only be used with cirkit (CK10 contract) tables

For non cirkit table see data sheet - "cirkit screen system (part 1)"

cirkit - screen sizes

(Part 2) Cirkit table fixed screens

screen sizes
front view

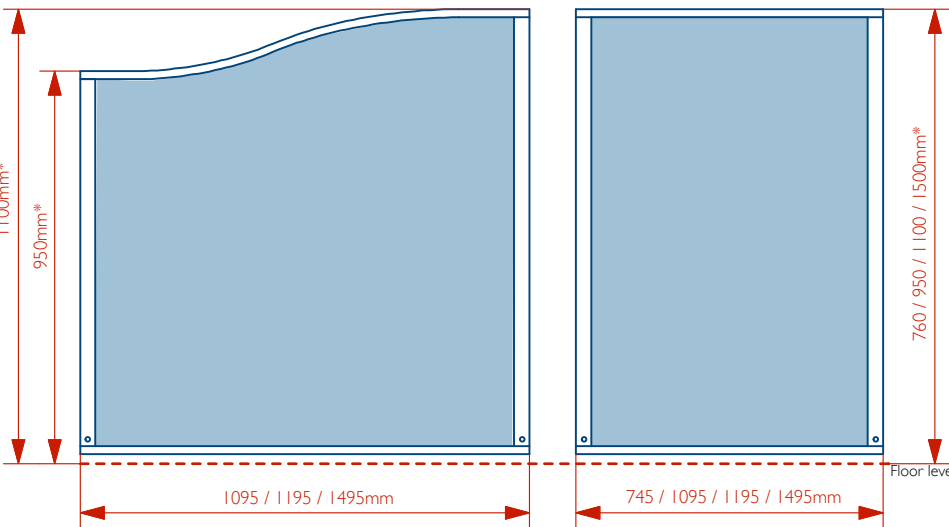

* Total height of screen when fitted to cirkit base or add-on tables

More information on sight-line heights for different age groups can be viewed on the school furniture uk website at www.schoolfurniture.uk.com

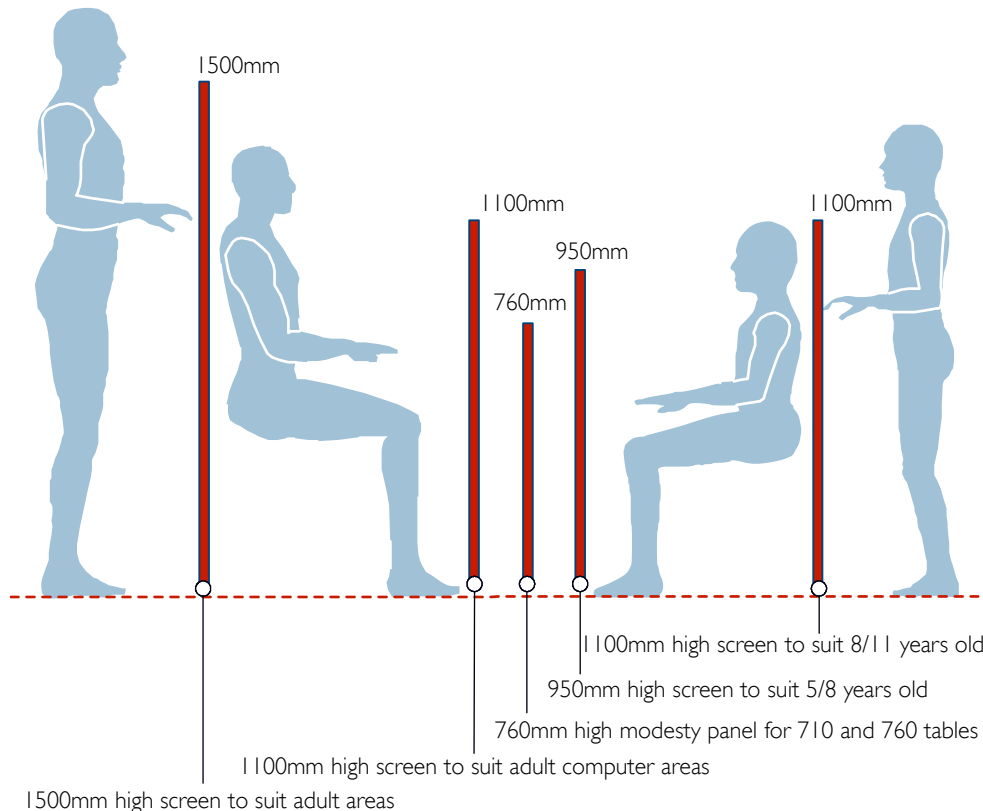

A comprehensive range of widths and heights are available to suit most needs. Screens are available in 4 heights and 4 widths

Curved top screens			
length	width	height	cat ref
1495	20	1100mm	3250
1190	20	1100mm	3251
1095	20	1100mm	3252

Flat top screens			
length	width	height	cat ref
1495	20	950mm	3261
1195	20	950mm	3266
1095	20	950mm	3271
745	20	950mm	3276
1495	20	1100mm	3260
1195	20	1100mm	3265
1095	20	1100mm	3270
745	20	1100mm	3275
1495	20	1500mm	3259
1195	20	1500mm	3264
1095	20	1500mm	3269
745	20	1500mm	3274

Modesty panels			
length	width	height	cat ref
1495	20	760mm	3240
1195	20	760mm	3241
1095	20	760mm	3242
745	20	760mm	3243



METALLIFORM
Chambers Road
Hoyland, Barnsley
S74 0EZ

tel. 01226 350555

[cfg] reserves the right to amend details and specification in this brochure

cirkit - screen fitted to base table

(Part 2) Cirkit table fixed screens

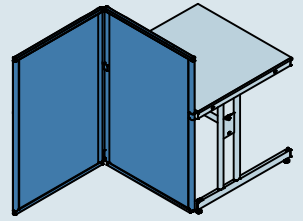

Matching screens and tables

plan view

screens	745mm	1095mm	1195mm	1495mm	1195mm	1195mm	1495mm	1495mm
tables	750mm	1100mm	1200mm	1500mm	2400mm		3000mm	

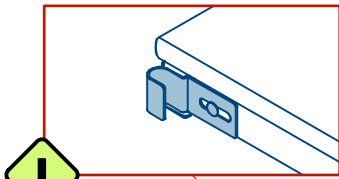

Bolt 2 x bracket (type A) to rear of the top frame. Do not fully tighten-up bolts until screen has been fitted. (Nut must be on the inner face of the table frame)

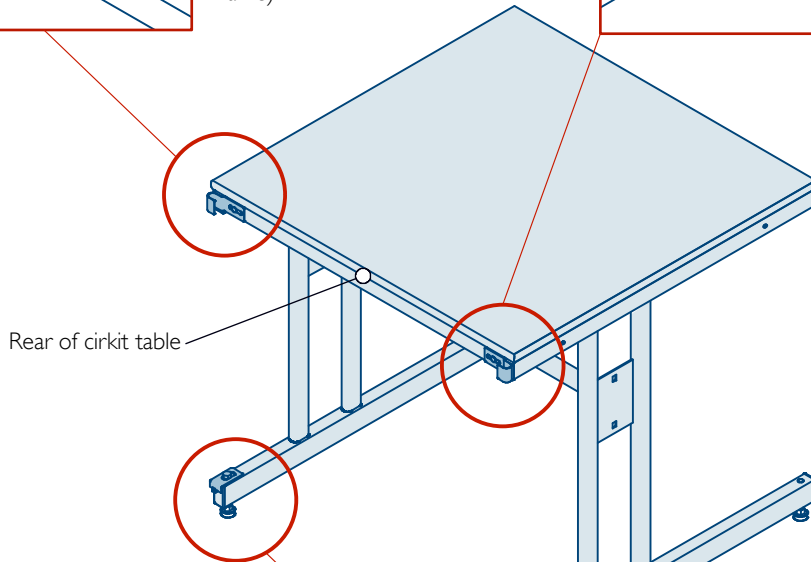
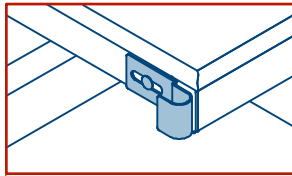

Rear of cirkit table

2

Next bolt 2 x bottom bracket (type B) to the rear of both leg frames using M10 bolts supplied

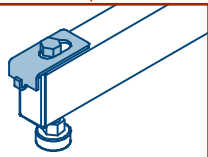

3

Slide screen between top fixing brackets onto bottom bracket lugs, so each single lug locates into the screen frame fixing holes.

4

Slide top bracket inward to hold screen and tighten-up bolts

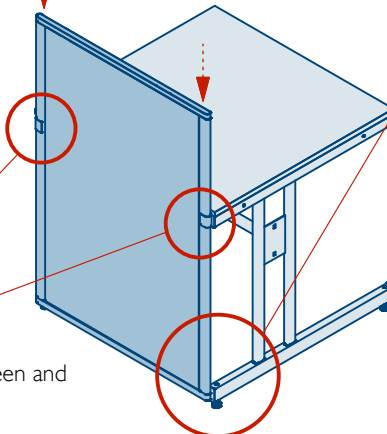

1

Screen pack 1 - ref 3285

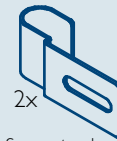

2x

Screen top bracket type A



M8 coach bolt, washes & hexagon nut

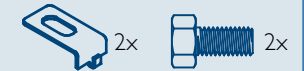

Single bracket type B.

M10 short hexagon headed bolt.

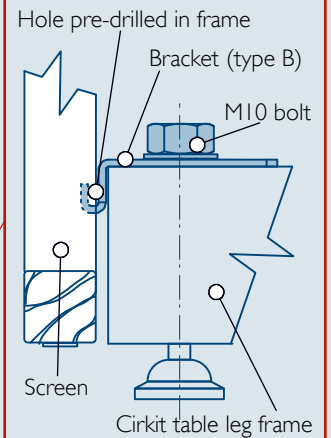

METALLIFORM
Chambers Road
Hoyland, Barnsley
S74 0EZ

tel. 01226 350555

[cfg] reserves the right to amend details and specification in this brochure

circuit - screen fitted to add-on's

(Part 2) Circuit table fixed screens

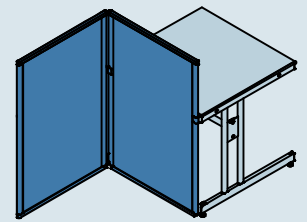

Matching screens and tables

plan view

screens	745mm	1095mm	1195mm	1495mm	1195mm	1195mm	1495mm	1495mm
tables	750mm	1100mm	1200mm	1500mm	2400mm		3000mm	

2 Screen pack 2 - ref 3286

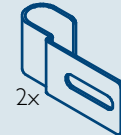

2x

Screen top bracket type A



M8 coach bolt, washes & hexagon nut

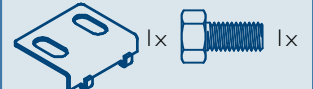

Single bracket type B1.

M10 short hexagon headed bolt.

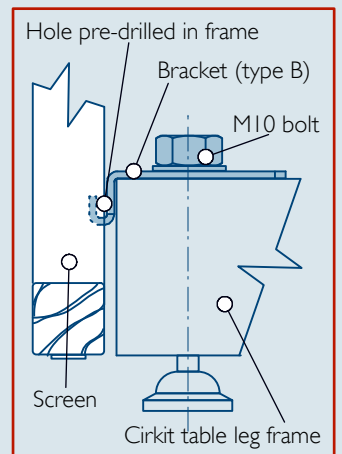
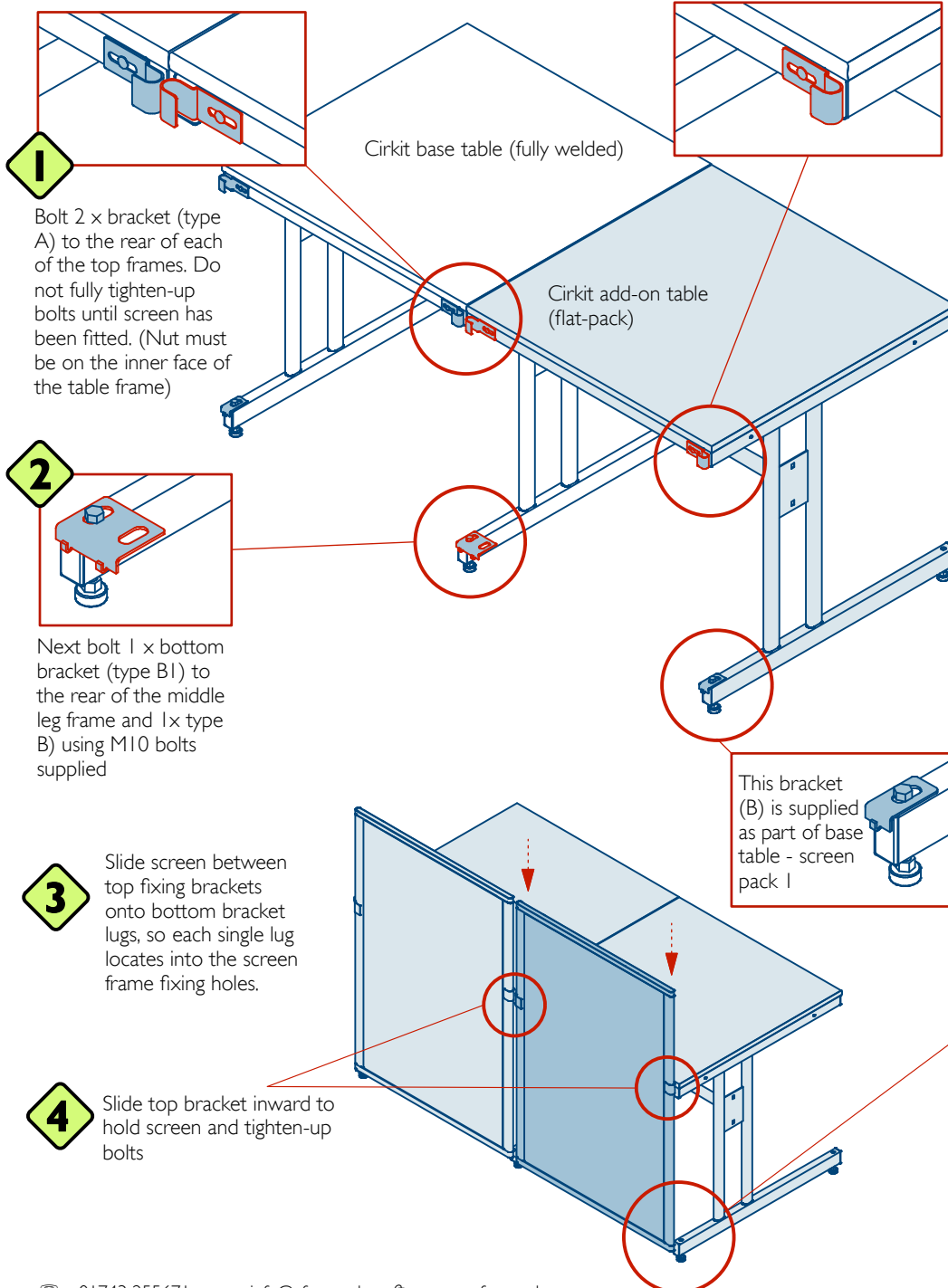

METALLFORM
Chambers Road
Hoyland, Barnsley
S74 0EZ

tel. 01226 350555

[cfg] reserves the right to amend details and specification in this brochure

circuit - screen fitted to end of table

(Part 2) Circuit table fixed screens

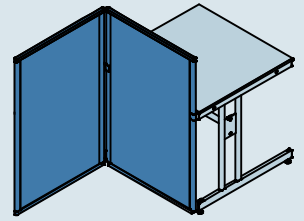

3

Screen pack 3 - ref 3287

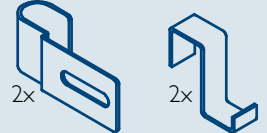

2x

2x

Screen top bracket type A

Bottom bracket type D (no fixings required)



M8 coach bolt, washes & hexagon nut

Matching screens and tables
plan view

screens	745mm	1095mm	1195mm	1495mm	1195mm	1195mm	1495mm	1495mm
tables	750mm	1100mm	1200mm	1500mm	2400mm		3000mm	



1
Bolt 2 x bracket (type A) to side of the top frame. Do not fully tighten-up bolts until screen has been fitted. (Nut must be on the inner face of the table frame)

2
Next hook brackets (type D) over leg frame

3
Slide screen between top fixing brackets down onto bottom brackets (see detail)

4
Slide top bracket inward to hold screen and tighten-up bolts

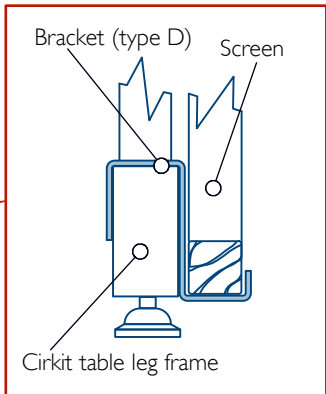
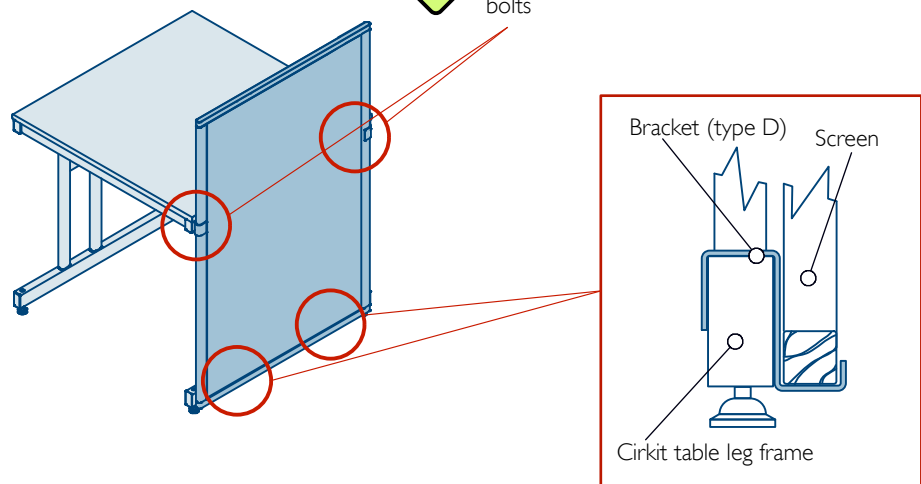

METALLIFORM
Chambers Road
Hoyland, Barnsley
S74 0EZ

tel. 01226 350555

[cfg] reserves the right to amend details and specification in this brochure

cirkit - screen fitted to corner table

(Part 2) Cirkit table fixed screens

Matching screens and tables

plan view

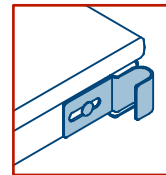
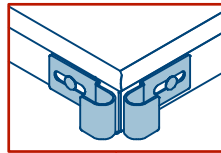
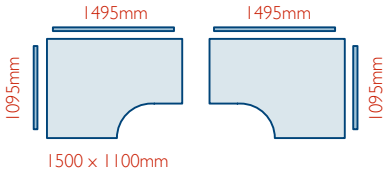

1

Bolt 2 x bracket (type A) to rear of the top frame. Do not fully tighten-up bolts until screen has been fitted. (Nut must be on the inner face of the table frame)

2

Next bolt 2 x bottom bracket (type B) to the rear of both leg frames and 1x bracket (type C) to middle leg frame using M10 bolts supplied

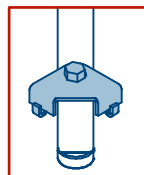

3

Slide screen between top fixing brackets down onto bottom bracket lugs, so each single lug locates into the screen frame fixing holes. Repeat for both screens

4

Slide top bracket inward to hold screen and tighten-up bolts

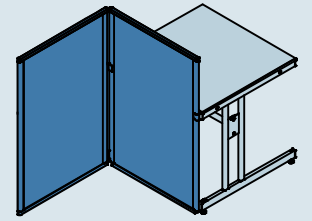

1

Screen pack I - ref 3285

2x
Screen top bracket type A

2x
M8 coach bolt, washes & hexagon nut

2x
Single bracket type B.
M10 short hexagon headed bolt.

1x
Corner bracket type C
M10 short hexagon headed bolt.

This bracket is supplied pre-fitted with all corner tables

Hole pre-drilled in frame

Bracket (type B)
M10 bolt
Screen
Cirkit table leg frame

manufactured by



METALLIFORM
Chambers Road
Hoyland, Barnsley
S74 0EZ

tel. 01226 350555

[cfg] reserves the right to amend details and specification in this brochure