

re work - bench overview

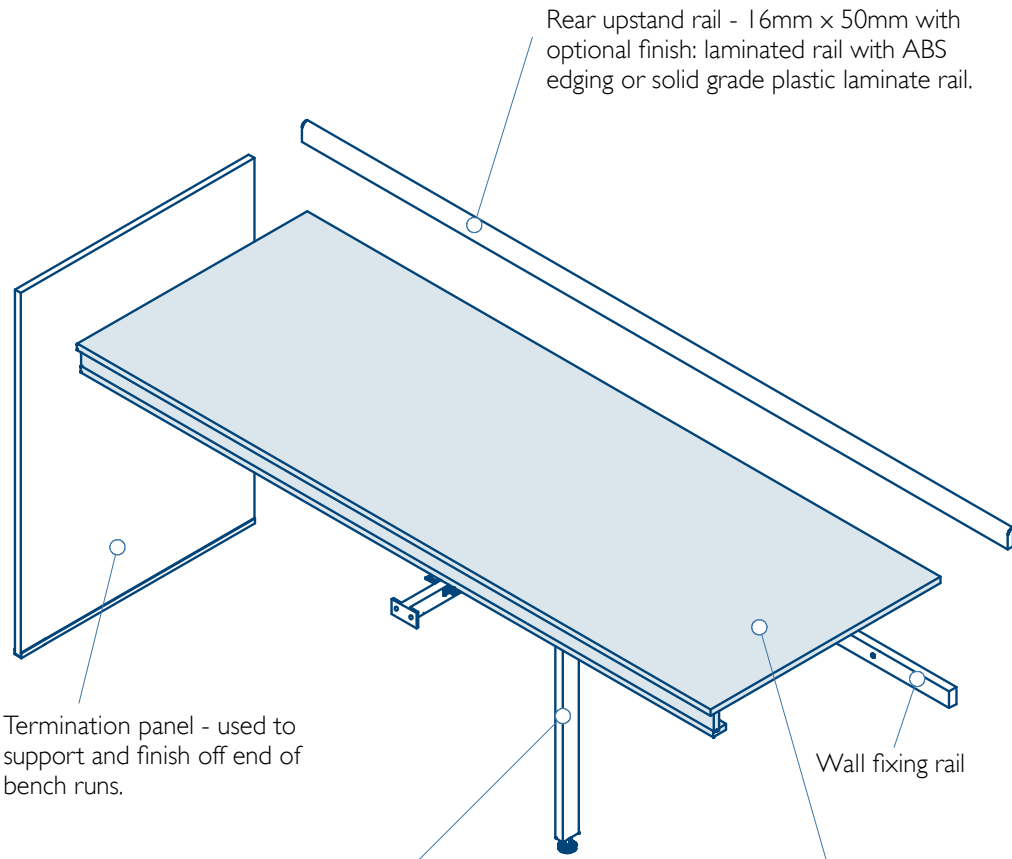

Re:work bench top is fixed to softwood wall batten and is supported on steel legs or on re:store carcasses. Re:work bench tops are constructed from either 16mm solid grade plastic laminate or 16mm laminated chipboard faced with 3mm ABS edging.

Re:work bench top is fixed to softwood wall batten and is supported on steel legs or on re:store carcasses. Re:work bench tops are constructed from either 16mm solid grade plastic laminate or 16mm laminated chipboard faced with 3mm ABS edging.

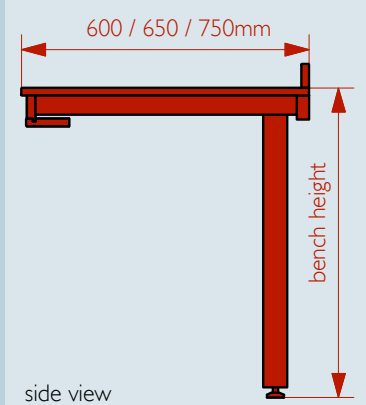
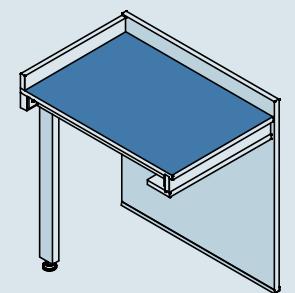

side view

sizes:

bench Ht	bench D	bench W
600mm*	600mm	2550 / 3025
	650mm	3025
	750mm	3025
650mm*	600mm	2550 / 3025
	650mm	3025
	750mm	3025
725mm*	600mm	2550 / 3025
	650mm	3025
	750mm	3025
775mm*	600mm	2550 / 3025
	650mm	3025
	750mm	3025
850mm*	600mm	2550 / 3025
	650mm	3025
	750mm	3025
900mm*	600mm	2550 / 3025
	650mm	3025
	750mm	3025

*Total height when fitted on leg supports or re:store units

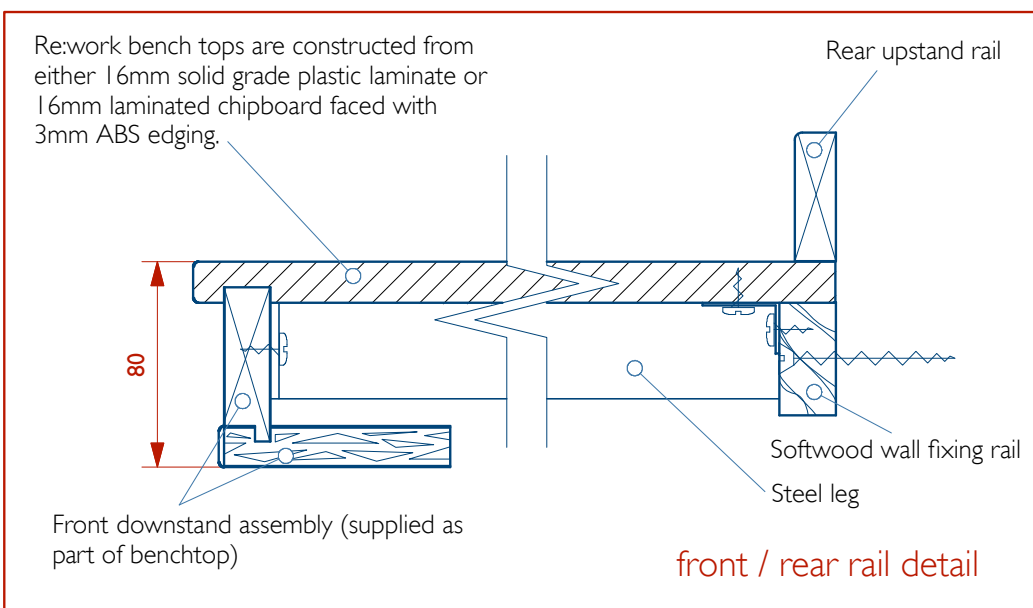

re store
re work

manufactured by

BRITISH THORNTON

[cfg] reserves the right to amend details and specification in this brochure

re work - bench assembly (part 1)

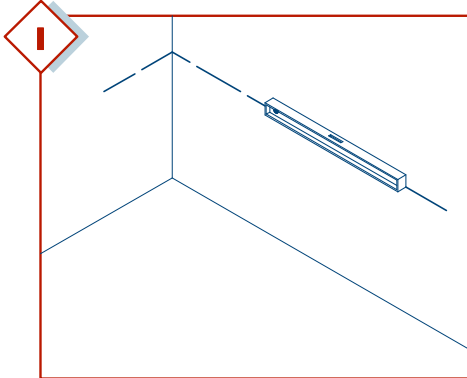

Measure and mark a level horizontal line on the wall where the new bench top is to be positioned. The height of the line should be marked at the height of the bench less the top thickness of 16mm

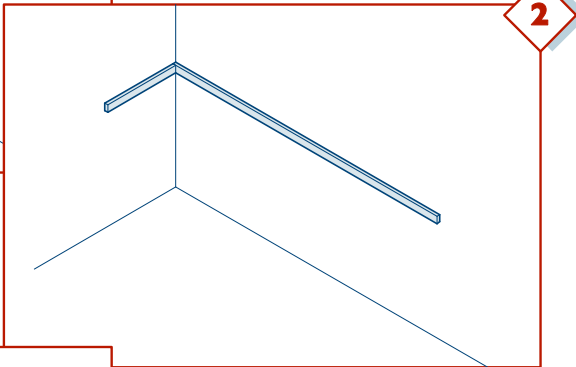

The 44 x 22mm softwood wall-fixing rail should be cut to size and fixed with suitable screws and plugs to the underside of the marked wall line.

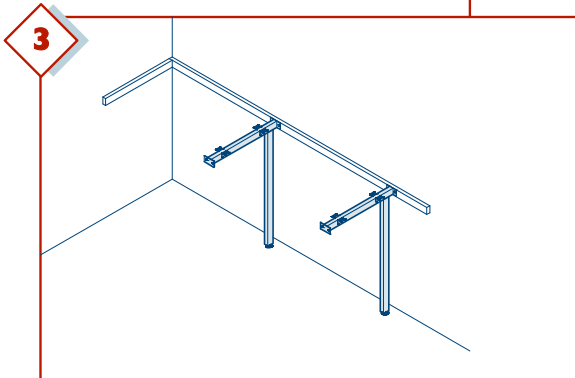

Leg supports are now fitted at 900mm centres (but not greater than 1000mm). Adjust the bottom foot of each leg so that the top of the leg is level with the top of the fixing rail. At this stage only fix the leg to the wall rail.

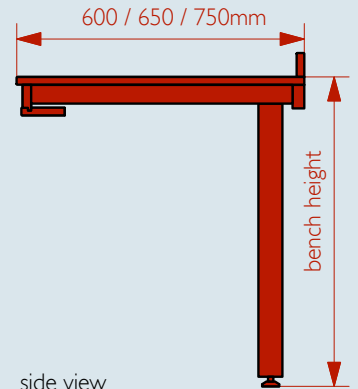
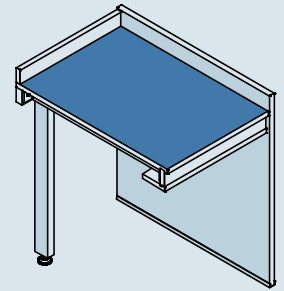
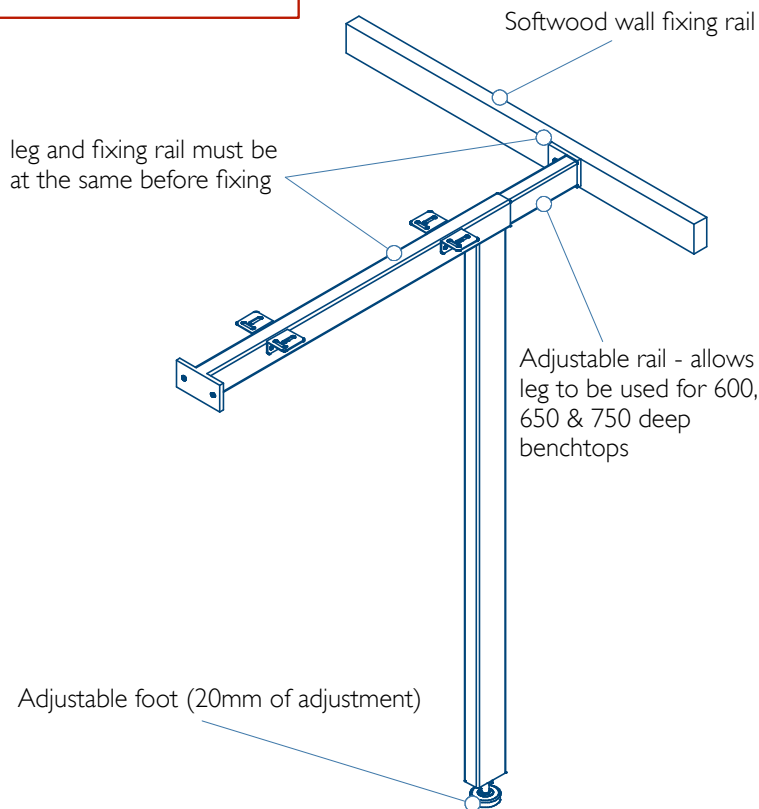

side view

sizes:

bench Ht	bench D	bench W
600mm*	600mm	2550 / 3025
	650mm	3025
	750mm	3025
650mm*	600mm	2550 / 3025
	650mm	3025
	750mm	3025
725mm*	600mm	2550 / 3025
	650mm	3025
	750mm	3025
775mm*	600mm	2550 / 3025
	650mm	3025
	750mm	3025
850mm*	600mm	2550 / 3025
	650mm	3025
	750mm	3025
900mm*	600mm	2550 / 3025
	650mm	3025
	750mm	3025

*Total height when fitted on leg supports or re:store units

re store

re work

manufactured by

BRITISH THORNTON

[cfg] reserves the right to amend details and specification in this brochure

re work - bench assembly (part 2)

Fix angle brackets at 300mm centres to wall fixing rail as shown right. Bench top can now be placed into position so that the downstand groove is facing down on the front edge and the bench is supported on the legs and wall-fixing rail. Now secure the rear of the bench to the wall rail using the angle brackets previously fixed and 16 x 4mm csk screws.

Next fix the front downstand rail into the groove with Acetoxysilicon and clamp into position. Adjust the leg support so the front fixing butts up to the inner face of the front downstand rail and fix with 2no. 16 x 4mm csk screws per leg. Check all legs are level and adjust if necessary using the adjustment feet. Screw fix through the support leg-fixing bracket into the bench top using 16 x 4mm csk screws and when fitting the screw be extremely careful not to pierce the top of the bench (see fixing details).

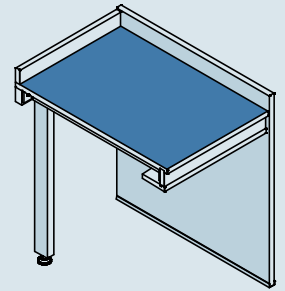
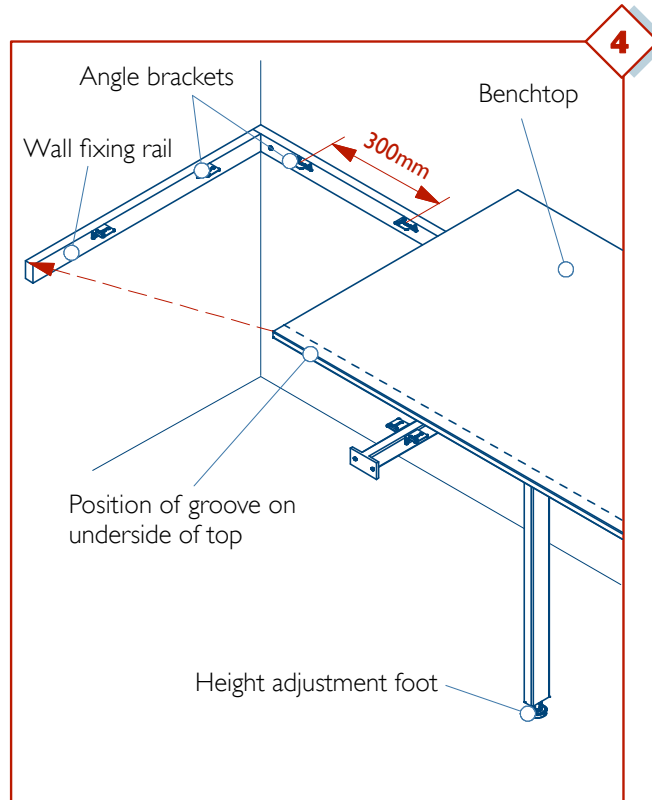

Top / panel is secured using a clear Acetoxysilicon (iso 11600-G.12.5hm)

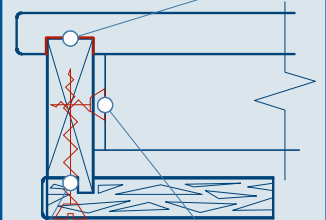

Panels screw fixed using 40 x 4mm csk screws
Leg / panel screw fixed using 16 x 4mm csk screws

Rear upstand rail is fixed in place using a clear Acetoxysilicon (iso 11600-G.12.5hm)

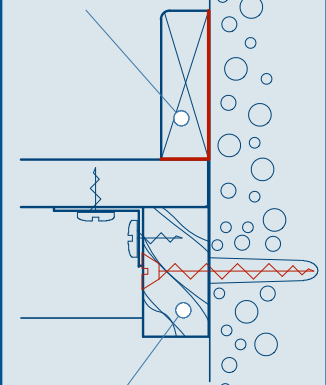

44 x 22mm softwood wall fixing rail (screw fixed)

Fixing details

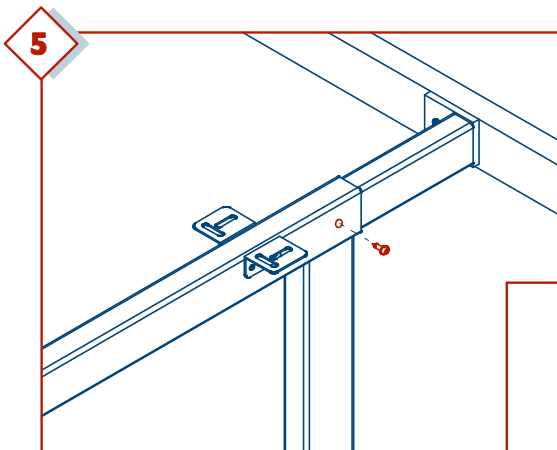

When the legs have been correctly positioned and fixed, drill a 3mm hole through the leg and telescopic part and fix using a 16 x 4mm self tapping screw.

Cut and fix rear upstand rails to the back of the bench and secure with Acetoxysilicon (see fixing detail). Finish of ends of bench runs with termination / end panels

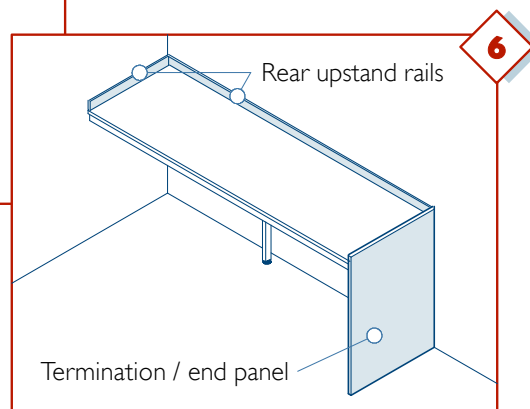

re store

re work

manufactured by

BRITISH THORNTON

[cfg] reserves the right to amend details and specification in this brochure

re store - under bench storage

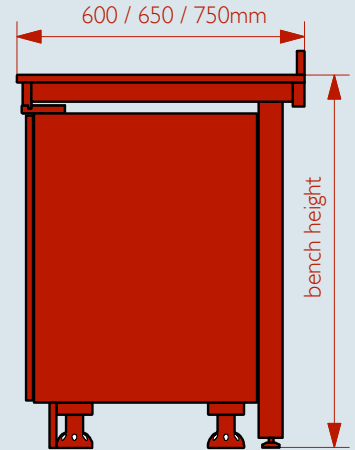
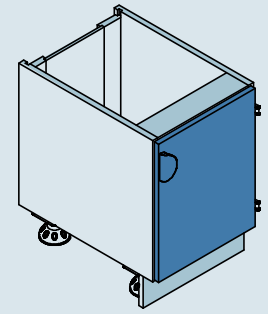
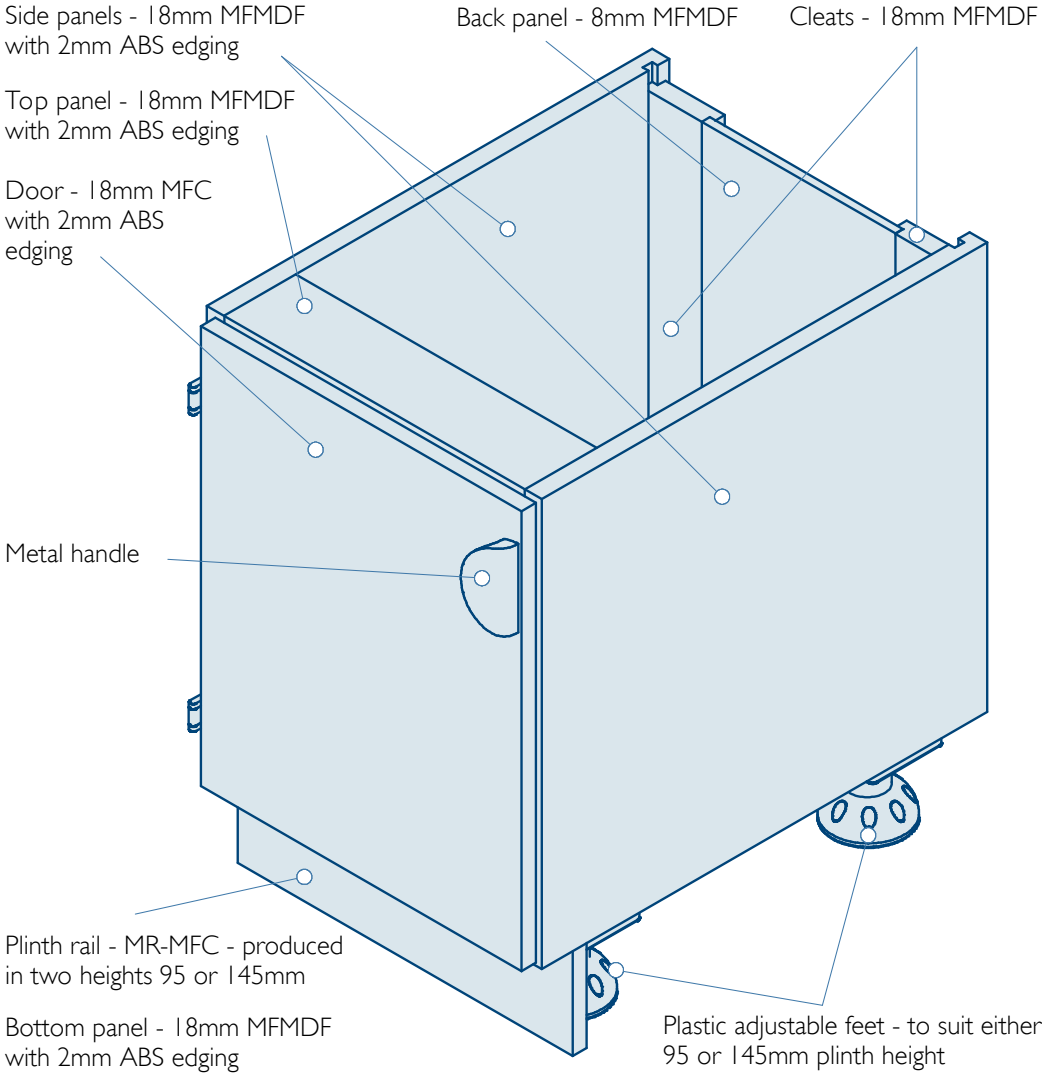

side view

sizes:

carcase ht	plinth ht	bench ht
520mm	95mm	600mm
570mm	145mm	650mm
645mm	95mm	725mm
695mm	145mm	775mm
770mm	95mm	850mm
820mm	145mm	900mm

carcase width	carcase depth
350mm	465mm
512mm	465mm
1010mm	465mm

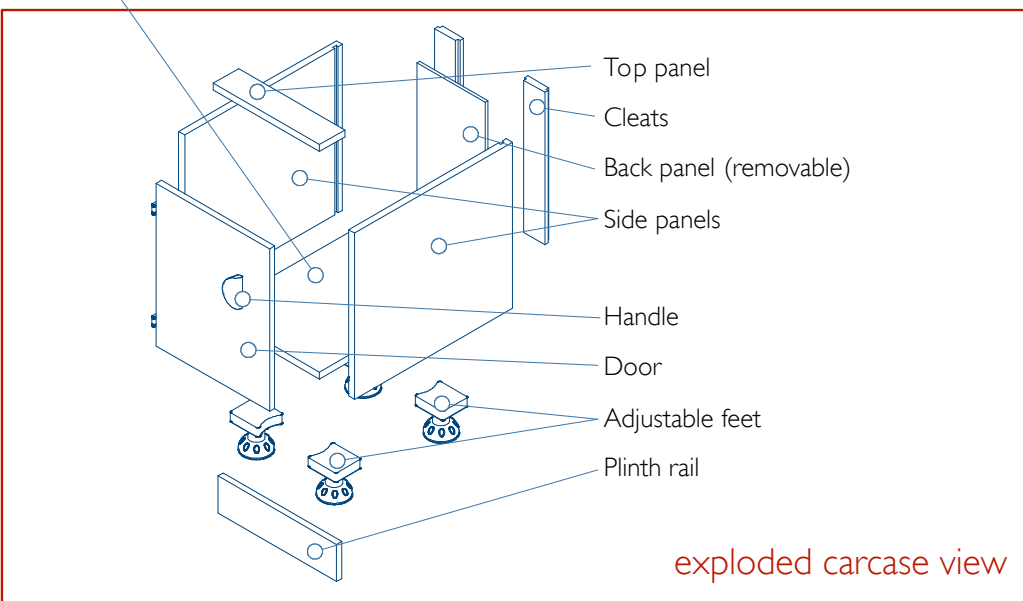

re store

re work

manufactured by



[cfg] reserves the right to amend details and specification in this brochure

re move - mobile storage

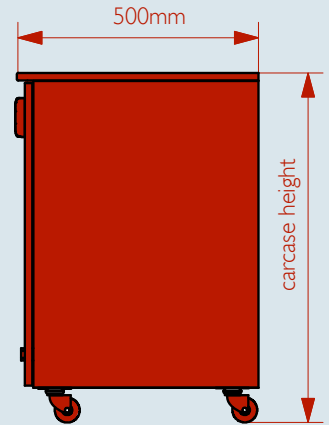
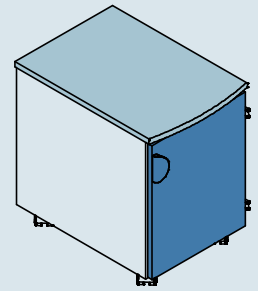
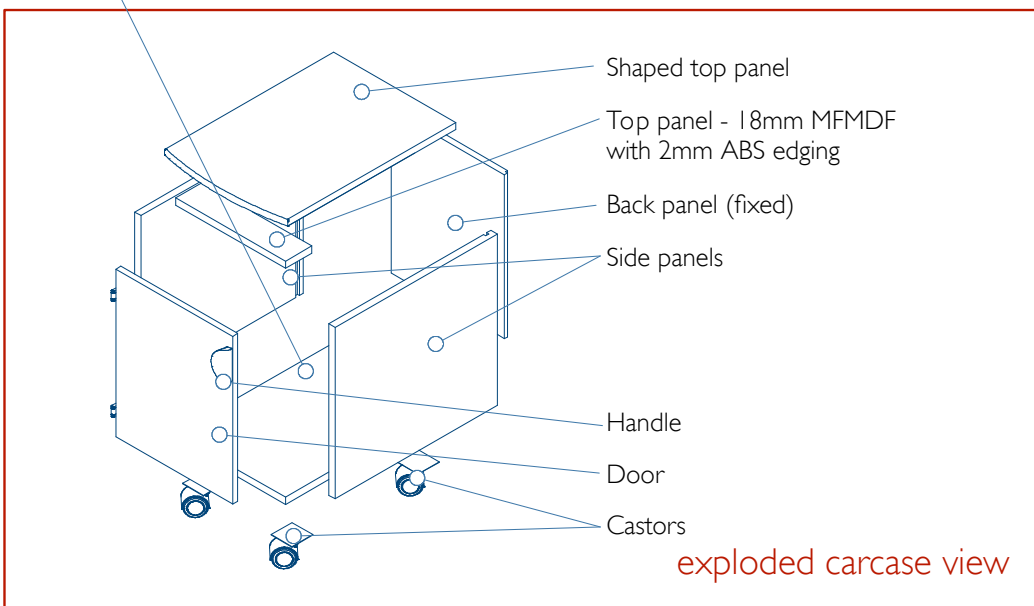
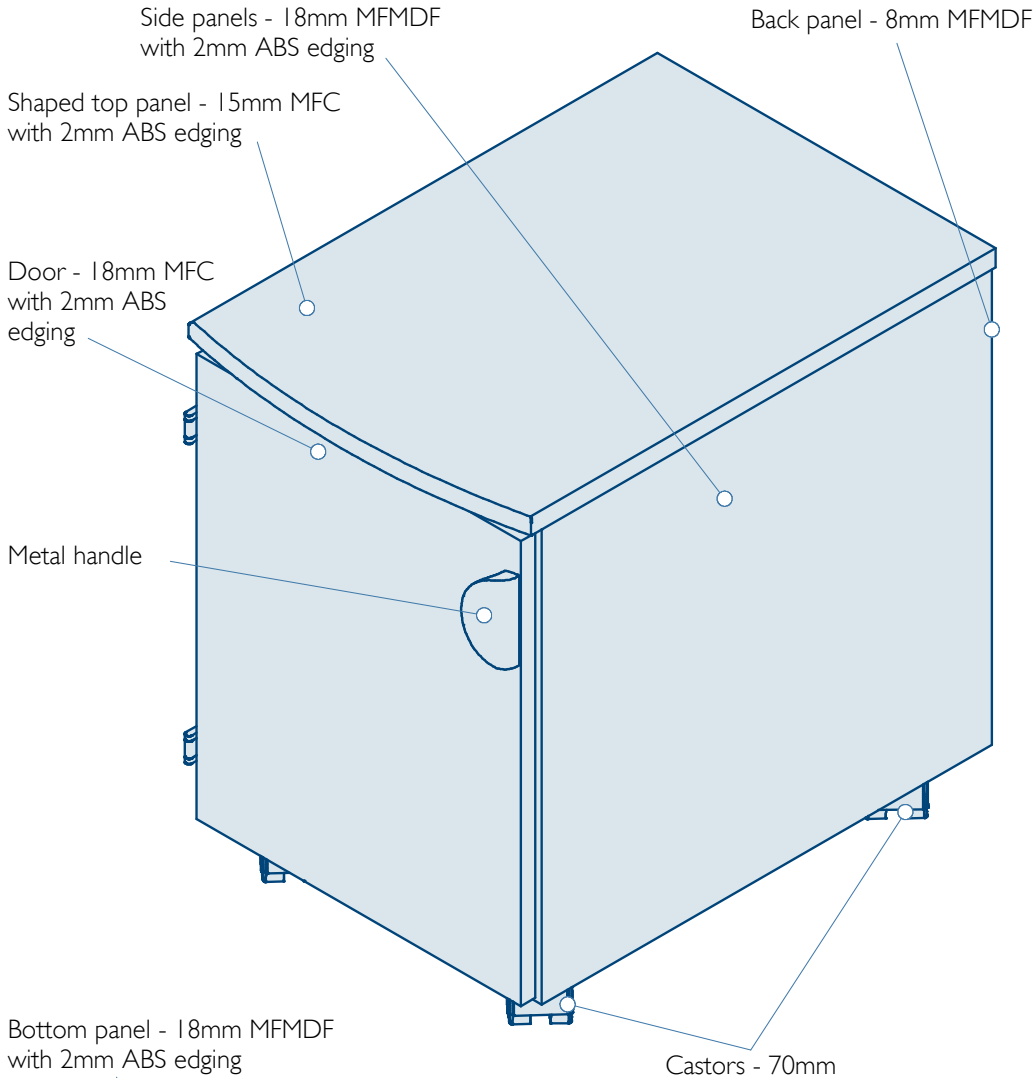

side view

sizes:

carcass ht	castor ht
511mm	70mm
636mm	70mm
761mm	70mm

carcass width	carcass depth
350mm	465 (500*)mm
512mm	465 (500*)mm
1010mm	465 (500*)mm

*overall depth of top

re move

manufactured by

BRITISH THORNTON

[cfg] reserves the right to amend details and specification in this brochure